



**HEALTH MATE**

# therapy lounge

owner's manual

HM-NSE-5-CD-CL



operating instructions for your  
Health Mate<sup>®</sup> far infrared sauna

---

## **guidelines and helpful tips**

Congratulations on your purchase of your Health Mate<sup>®</sup> Far Infrared Sauna.  
We are confident that you will enjoy the many benefits for years to come.

Carefully read this manual before using your Health Mate<sup>®</sup> Sauna for the first time. We recommend keeping this manual for review and future reference.



# health mate®

the leader of infrared wellness since 1979

Welcome to the Health Mate® Family!

As the leading creator of infrared sauna wellness for nearly 35 years, Health Mate® Far Infrared Sauna continues to provide excellent craftsmanship and innovative technology.

We attribute this growth and success entirely to our customer satisfaction, the recognized health benefits, and the quality of our superior craftsmanship. At Health Mate®, we use only the finest materials combined with state-of-the-art construction and the highest safety standards in the industry.

Within the family of Health Mate collections, enjoy such features as our patented and 10-year-warranted TECOLOY® infrared heaters, responsibly and sustainably certified wood, LED color lighting, Bluetooth® compatible audio components, and additional characteristics designed to treat the needs of one's lifestyle and wellness.

We are so happy to have you join us and look forward to sharing in your experience as you revitalize with the difference Health Mate® provides: a difference in benefits, quality, and attitude as we support you along your journey through health and wellness!

Happy healing to you and your new mate,

Your Health Mate® Family

HM® Headquarters, California



# table of contents

a	Installation and Maintenance:	1. Location, Cleaning & Maintenance .....	4
		2. Assembly Guide .....	5
b	Getting Started .....		12
c	Helpful Tips for Enjoying Your Sauna Sessions .....		18
d	Safety Precautions for Your Health Mate Sauna .....		21
e	Troubleshooting Guide .....		23
f	Optional Accessories:	a. Outdoor Cover .....	26
g	Limited Warranty .....		30

The information contained in this manual is subject to change without notice.



## a. installation & maintenance

### 1) choosing a location

---

In determining a location for your Health Mate Infrared Sauna, there are two important things to keep in mind: First, the sauna should always be placed on a level surface. Second, the sauna must be placed in a dry area.

The installation requirements for your Health Mate Infrared Sauna are as follows:

1. Your Health Mate cabin is intended to be a self-contained and freestanding unit. It must not be built into to any structure.
2. There should be a minimum of 5-inches / 12,5 cm clearance from the wall on all sides of the unit to allow easy access to the main power cord.

Moisture may cause damages to the interior and exterior of the sauna. Basement, attic, garage, playroom, spare bedroom, new extension and garden chalet are just a few of possible locations for your sauna. Health Mate's beautiful and simple wooden exterior will compliment the interior of your house beautifully.

If you prefer an outdoor environment, you must use a cover (see page 26) to protect your sauna. Do not place the sauna on a surface that easily gets wet. Placing your sauna outside without a Health Mate cover will void your warranty.

### 2) cleaning & maintenance

---

1. Before using your Health Mate Infrared Sauna for the first time, clean the inside of the sauna with a damp cloth. When cleaning the exterior, use a natural furniture polish.
2. We recommend turning the sauna on for the maximum time and temperature in order to burn off any factory dust prior to using the sauna for the first time. For maximum heater performance please cycle your Health Mate (turn on to max temperature and run for one hour), 2-3 times.
3. Scratches and stains on the inside of the sauna can be removed by simply using a fine grade sandpaper over the damaged area.
4. A customized Health Mate Sauna Cover is available as an accessory for all models. Use of this protective storage cover will not only preserve the natural beauty of the sauna, but will also help in maintaining years of continuous enjoyment.
5. We recommend applying a heavy furniture polish to the outside of the sauna before putting the (optional) cover on. Use of a polish will create a barrier for better protection.



## a. installation & maintenance

### 3) assembly guide

Assembly of the sauna requires 2-3 adults depending on model to complete. Please read the instructions thoroughly before and during assembly to ensure proper installation of the unit. If you encounter any problems or have questions during the assembly, please feel free to call for Technical Support: (714)739-6600

#### step 1: bottom and back panels

1. **Open box b** to find the bottom panel.

Turn the bottom panel upside-down and install the feet



Turn the bottom panel back over and place it in position where the sauna will be assembled.



2. Push the female end of the main power cord up through the square hole in the left rear corner of the bottom.

3. Place the back right panel onto the bottom panel. Have someone hold the back panel upright so it does not fall over.



4. Place the back left panel onto the bottom panel. Use the C clips to clip the back panels together.





## a. installation & maintenance

5. Secure back panels with (2) provided screws. One extra is provided.



### step 2: right panel and bench

1. Place the right side panel on base. Buckle the side panel to the back wall and bottom panel.
2. Set small bench base into back wall slot. Set large bench base with heaters facing outward.





## a. installation & maintenance

### step 3: heater connections

1. Plug the right wall cable into the back wall outlet located in the far right of the sauna.



4. From the hole in the floor, take the short heater cable labeled "HEATER" and plug into power supply.



2. Plug the cable coming out of the bench heater into any of the 4 "HEATER" sockets on the power supply mounted in the back panel. This cable is not marked.

3. Plug the cable coming out of the right back wall into any of the 4 "HEATER" sockets on the power supply mounted in the back panel. This cable marked "HEATER".



5. From the hole in the floor, take the long heater cable and plug into the bench heater connector.







## a. installation & maintenance

### step 4: bench connections

1. Lay the first section of the bench on top of the bench base as shown.
2. Plug in additional heater cable labeled "2" into bench base.
3. Connect bench heater connector to bench heater connector, circled.



4. Lay the second bench down half way and connect the heater cable labeled "4".

5. Lay the second bench snug against first section bench.

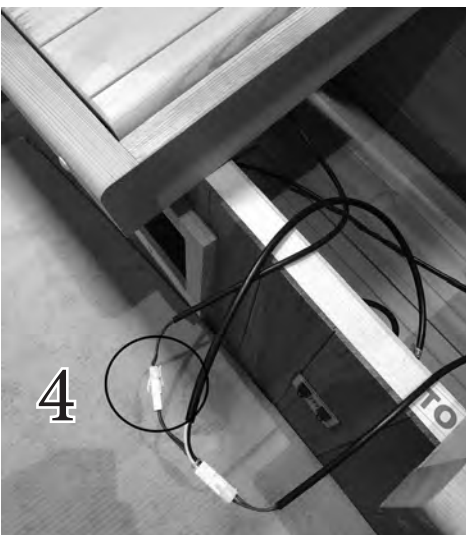





## a. installation & maintenance

### step 5: front panels

1. Place right panel on base of sauna and buckle the two pieces together.



2. Connect the heater cable attached to the right front panel just installed to the right wall socket.

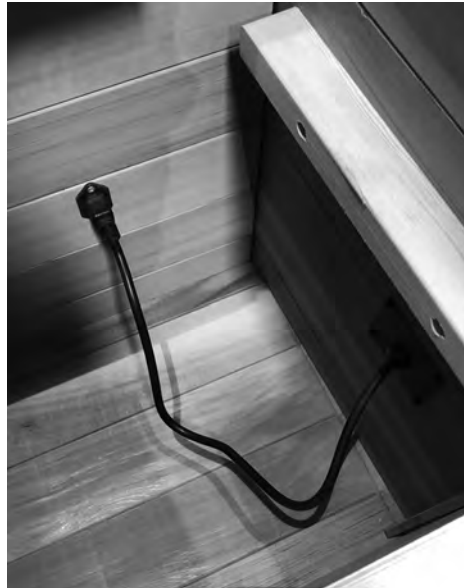

3. Take the front large panel with glass door and place on base. Be careful to not allow the door to swing and accidentally break the glass.

Carefully align the notch on the front panel with the hole on the base. Once in place, you will need to apply slight force and wiggle the door so the notch slides into the hole and is flush with the panel to the right.





## a. installation & maintenance

4. Use the provided screws to attach the front left panel with the front right panel.



### step 6: top panel

1. Set the top panel onto the sauna. Be careful not to pinch any cables between the top, side, and back panels. We recommend two people for this step.



4. Use the provided screws to attach the provided door handle to the front panel.





## a. installation & maintenance

### step 7: connections

1. Inside the sauna, there are two cables that emerge from the square opening in the bottom panel at the front. Plug the connectors from these cables into the "DATA" and "HEATER" sockets at the bottom of the front panel, being careful to match the shape of each plug to the shape of the socket. Examine the shape of the 3-wire heater plug very carefully, noting that one side of the plug has two slightly rounded edges. The "HEATER" socket on the front panel also has one side with two slightly rounded edges.

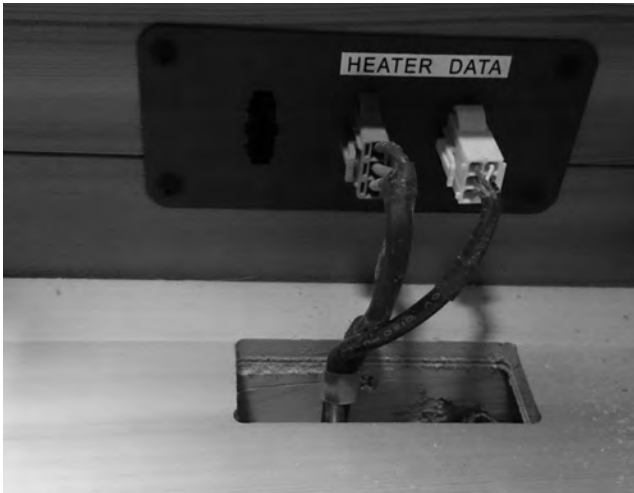

2. Place the magnetic wooden cover over the connection.

#### Note:

One of the two wooden covers features your sauna's serial number barcode sticker. Use this wooden cover on these front panel connections for ease of access to this information for your registration or after-service needs.

### your installation is complete

The installation of your new sauna is now complete! Using a damp cloth, wipe out the sauna to remove any excess sawdust that may have settled on the wall, heaters, or floor.

3. There are two cables emerging from the small square opening at the back of the top panel. Plug the "EXT" cable and the "LAMP" cable into the labeled open sockets on the back panel. **It is possible to plug these connections in upside down.** Make sure the shape of the plugs are aligned with the shape of the sockets.

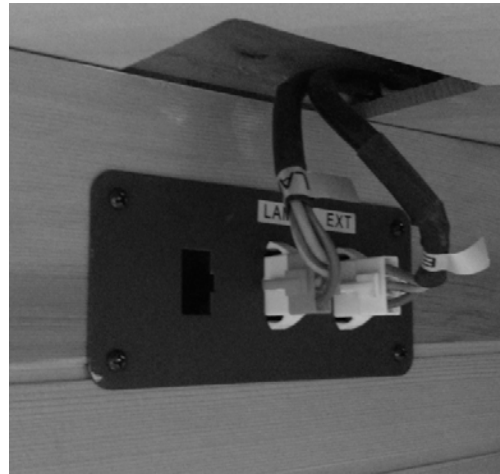

3. Place the second magnetic wooden cover over the connections.



# b. getting started

## 1) preparing for your first infrared sauna home experience .....

1. Review all health and safety instructions. If in doubt as to the advisability of using your infrared sauna, consult with your physician.

2. The interior & exterior of the Health Mate Infrared Sauna is made of the finest wood.

It is very aromatic and adds to the enjoyment of your sauna session. If the fragrance of the fresh wood is too strong during the first few months of usage, first wipe the wood with a damp cloth to minimize the aroma.

## 2) digital control panel .....

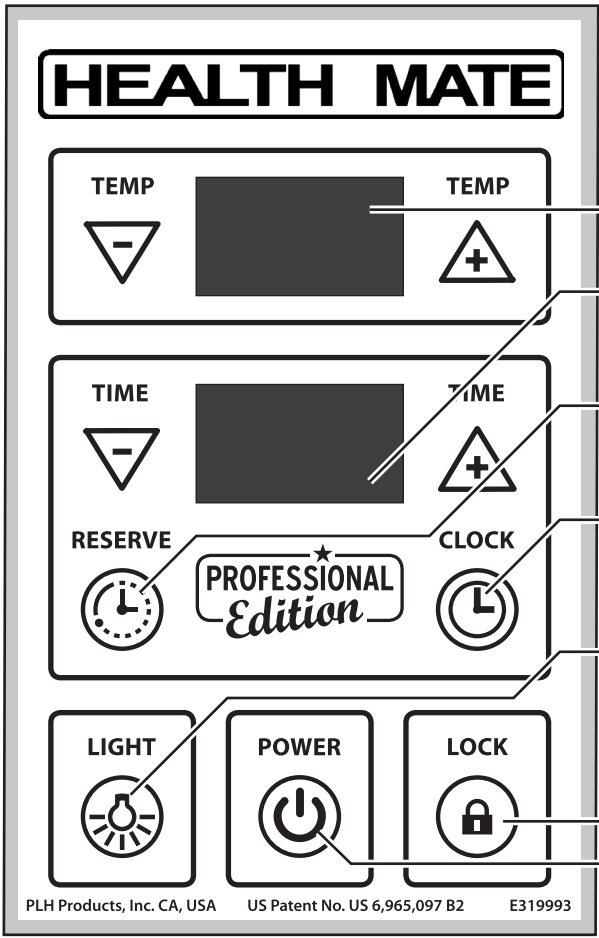

Temperature Display  
current sauna session temperature indicator 'F/'C

Time Display  
Off Mode: Current Time / On Mode: Sauna Session Time

Reserve Button  
Reserve Session, Functional When Powered Off

Clock Button  
Change Current Time During Off Mode

Light Button  
Turn Light On and Off, Functional When Powered On or Off

Lock Button  
Lock Sauna Controller

Power Button  
Turn Sauna On and Off

  
Controller is touch sensor type so please do not press the controller too hard!



## b. getting started

### 3) powering up

1. Plug in the power cord to the electrical outlet. All lights on the LED Control Panel will flash once.
2. During Off mode, only the Health Mate logo and Current Time will display.
3. We recommend turning the sauna on for the maximum time and temperature in order to burn off any factory dust prior to using the sauna for the first time. For maximum heater performance please cycle your Health Mate (turn on to max temperature and run for one hour), 2-3 times.

### 4) setting current time

1. While the power is turned Off, the current time will be displayed.
2. During Off mode, double-tap the Clock button until the display flashes.
3. When the clock has been set to the desired time, wait 3 seconds and the clock will be set.

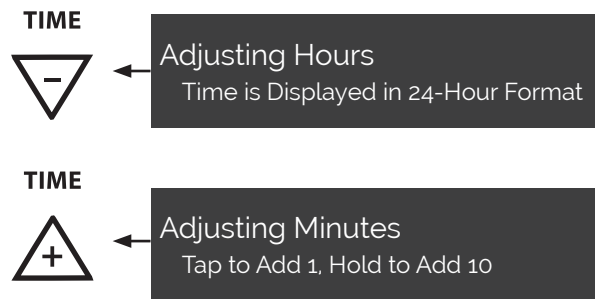

### 5) starting up your sauna

1. Tap and hold the Power button for approximately 5 seconds to start up your sauna.
2. The temperature display will indicate the current cabin temperature. If the ambient temperature within the cabin is below 90°F/30°C, the display will read "LO".
3. The time display will indicate the sauna session time. When the time button is tapped, it will change the time in five minute increments. Maximum session time is 60 seconds.
4. The Light button will illuminate to indicate that the interior LED panel is turned on. To turn Off, simply tap Light again.



## b. getting started

### 6) setting the sauna session time and temperature

#### Session Time

1. Tap the Time+ or Time- buttons to adjust the sauna session time.
2. The session time will change in 5 minute increments and can be set between 5 and 60 minutes per session.

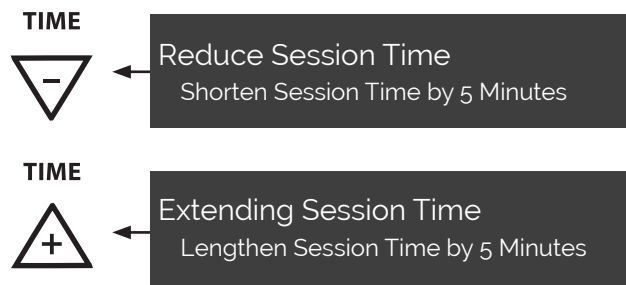

#### Session Temperature

1. Tap the Temp+ or Temp- button to adjust the sauna session temperature.
2. In Fahrenheit mode (°F) the temperature can be adjusted 5 degrees at a time.  
**Min. Temp: 90°F, Max Temp: 170°F**
3. In Celsius mode (°C) the temperature can be adjusted 1 degree at a time.  
**Min. Temp: 30°C, Max Temp: 75°C**



### 7) change between fahrenheit and celsius

1. Tap and hold the Power button for approximately 5 seconds to start up your sauna.
  2. Tap the Temp- and Temp+ buttons **at the same time** and hold for approx. 5 seconds until the display reads "F-C".
  3. Tap the Temp- and Temp+ buttons **at the same time** to change to the desired mode (°F or °C).
  4. Tap the Temp- and Temp+ buttons **at the same time** and the display will read "OST".
  5. Tap the Temp- and Temp+ buttons **at the same time** and the display will read "S-L".
  6. Tap the Temp- and Temp+ buttons **at the same time** once more and the display will show the current temperature.
- Note:**  
 If the display shows "S" and the controller is beeping, simply repeat steps 2-5 and tap the Temp- and Temp+ buttons **at the same time** until the display reads "L". Then tap the Temp- and Temp+ buttons one last time.



## b. getting started

### 8) schedule a reserve sauna session

1. During Off mode, double-tap the Reserve button until the display flashes.
2. Use the Time+ and Time- to set the time of day for your future sauna session.

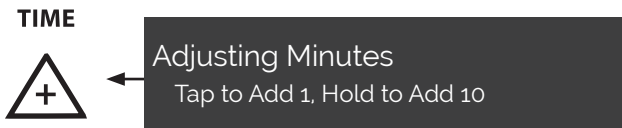
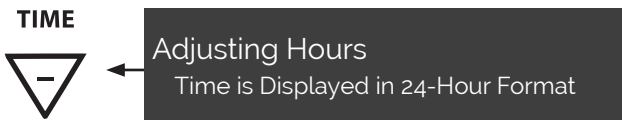

3. Once the desired time is chosen, wait approx. 3 seconds and the time will be set automatically.

4. During Off mode, when a sauna session time has been scheduled, the Reserve button will illuminate.
5. To check your scheduled session, tap the Reserve button once. Your reserved time will display for approx. 10 seconds.
6. To cancel your scheduled Reserve session, simply tap the Power button and turn on the sauna.
7. Your scheduled sauna session will begin with a beeping sound that lasts for approx. 5 seconds.
8. Your scheduled sauna session time will automatically set for 30 minutes and the temperature will set to match your previous session temperature. Time and temperature can be changed during your scheduled sauna session.

### 9) locking your sauna's control panel

1. Tap both the Lock and Temp- buttons at the same time and hold for approx. 5 seconds.
2. You will hear a beep and "LOCK" will appear on the upper right corner of the time display.
3. During Lock mode, all buttons will not be responsive in either On or Off modes and the Lock button will illuminate.
4. To release the Lock function, tap both the Lock and Temp- buttons at the same time and hold for approx. 5 seconds.

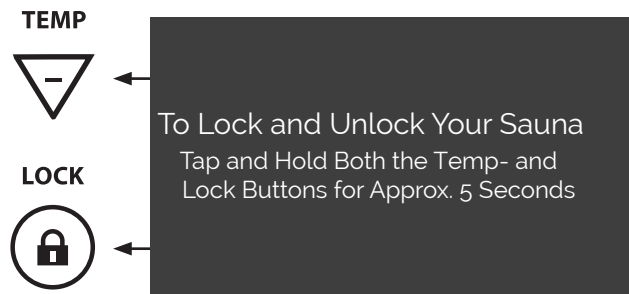





## b. getting started

### 10) changing your sauna's settings during a session .....

1. When your sauna is On, the interior light will illuminate automatically. To turn the light Off, tap the Light button.
  2. If you want to adjust the temperature during a session, tap the Temp+ or Temp- buttons.
  3. If you want to adjust the session time, simply tap the Time+ or Time- buttons.
  4. If you want to turn Off the sauna in the middle of a session, tap and hold the Power button until your sauna turns Off.
- When your sauna session is over, "END" will flash on the time display and you will hear 3 beeps. The sauna will turn Off automatically after 5 seconds.
  - Clock Time is not displayed while the sauna is in session. During your session, only the countdown of your session time is visible.
  - The Reserve and Clock buttons are not functional during the sauna session.

### 11) controlling the multi-color LED light .....

Touch the Light key at any time to turn the inside light on or off, regardless of whether the sauna is turned on.



#### multi color led light remote controller operating instructions

1. Press the **On** button to **turn on** your color light. The starting light color is White.
2. Press the **Off** button to **turn off** your color light.
3. When the color light is on, press the **Manual** button to **change the colors** of your color light manually.
4. When the color light is on, press the **Auto** button to **change the colors automatically** in sequence.
5. Press the - or + buttons to **change the brightness** of your color light.
6. Do not place your remote near heating elements.

**Color Sequence:** White > Red > Yellow > Orange > Green > Cyan > Blue > Purple > Pink

For more information on the color light in your Health Mate, please visit: [healthmatesauna.com](http://healthmatesauna.com)



## b. getting started

### 12) powering on the exterior light.....

To turn your sauna's exterior LED light On or Off, simply press the manual switch located on the ceiling inside your sauna.

### 13) powered sound system.....

Please refer to the AM/FM Radio & CD Player's manual for operation instructions.

### 14) error codes .....

**EO** EO: Temperature Sensor Disconnected.

**ES** ES: Temperature Sensor Short Circuit.

**IN CASE OF AN EO OR ES ERROR CODE, PLEASE CONTACT CUSTOMER SERVICE FOR FURTHER ASSISTANCE\***

**OHT** OHT: Inside Sauna Temperature is over the limit (180°F/82°C).

**OHR** OHR: Inside of Controller is overheated (180°F/82°C).

OHT and OHR error will be resolved automatically. During OHT and OHR error, your sauna will automatically shutdown and go into a cooldown period.

#### (\*) Contact Information for Customer Service

- Toll Free Phone No. in the U.S.A. : \_\_\_\_\_ (800) 946-6001
- Telephone No. : \_\_\_\_\_ (714) 739-6600
- Fax No. : \_\_\_\_\_ (714) 739-6605
- Email : \_\_\_\_\_ support@healthmatesauna.com

Support ticket recommended



# c. helpful tips for enjoying your sauna sessions

Your Health Mate Infrared Sauna is equipped with special infrared heaters. Infrared heat waves reach the body directly without having to heat the intervening air inside the sauna.

With this system, breathing is more comfortable and the atmosphere inside the sauna is more enjoyable than in conventional saunas. Because the infrared heat energy is warming the body directly (and not the air, walls, and fixtures within the sauna), lower temperature settings can be used to achieve results in short sessions starting from 20 to 30 minutes.

## 1) preparing for your infrared session .....

- 1. **Review all health and safety instructions.** If in doubt as to the advisability of using your infrared sauna, consult with your physician.
- 2. The interior of the Health Mate Infrared Sauna is made of the finest wood. It is very aromatic and adds to the enjoyment of your sauna session. If the fragrance of the fresh wood is too strong during the first few months of use, first wipe the wood with a damp cloth to minimize the aroma.
- 3. Always **drink plenty of water**, before, during and after a session. Doing so will replenish fluids lost during perspiration.
- 4. Do not eat anything at least an hour before your sauna session. It is better to **go in the sauna on an empty stomach**. You are more likely to feel uncomfortable sitting in a sauna with a full stomach.
- 5. **Choosing to take a hot shower or bath prior to the sauna session will further promote perspiration.** However, dry off thoroughly before going into the sauna because excessive water will leave stains and might warp the wood.

- 6. **Provide at least 2-3 towels.** One towel folded over several times for added cushioning on the bench. Another towel on the floor to absorb extra sweat. And a third towel to wipe off sweat.
- 7. **Start up your sauna and select the desired session temperature and time** using the control panel (see page 6 and next page).
- 8. **Allow approximately 15 to 20 minutes for the sauna to warm up** to a comfortable temperature before beginning a session (warm up time is subject to the air temperature and is different for each model).

Base Temperature (110-120 degrees)	Time
Renew Series	15-20 Min
Enrich Series	15-20 Min
Elevated/ Therapy Lounge	15-20 Min

**Please Note:** Your sauna's maximum temperature setting may not be achieved based on variations in ambient room temperature, air flow, placement of sauna, etc. If you are experiencing unusual warm-up times or if you have recently moved your sauna from one location to another, please call our technical support team for thermostat calibration help.





# c. helpful tips for enjoying your sauna sessions

## 2) setting session time and temperature

Your body will probably need a few weeks to fully adapt to a regular use of your Health Mate sauna.

Here are some average guidelines to set the time and temperature, once you are used to the sessions:

1.  **Time:**  
Noticeable results are usually obtained with sessions of at least 30 minutes. For therapeutic use, sessions of 45 minutes or more is advised.

2.  **Temperature:**  
Depending on your condition and personal preferences, session temperature is usually set between 120°F/50°C and 140°F/60°C. If perspiration does not start after 10 to 15 minutes, this usually indicates that the temperature is set too low to obtain good results.

Always make sure you feel comfortable at all times!

When using your Health Mate sauna for the first time:

- Do not do more than three sessions a week during the first four weeks. You can do daily sessions after six weeks, if desired.
- If you do not feel comfortable or relaxed during a session, lower the temperature and/or open the door of the cabin.
- Recommended schedule and settings for starters:

	TIME	TEMPERATURE
week 1	20 min	120°F/50°C
week 2	23 min	120°F/51°C
week 3	26 min	125°F/52°C
week 4	29 min	125°F/53°C
week 5	32 min	130°F/54°C
week 6	35 min	135°F/55°C



## c. helpful tips for enjoying your sauna sessions

### 3) useful information and tips for during your sauna session .....

1. **Make sure you have a towel on the floor and on the bench of the sauna to absorb perspiration.**

In order to maintain a clean and pleasant atmosphere inside of your sauna, do not leave damp towels on the bench or floor. Remove them immediately after the session is over.

2. Be sure to **towel off excess** sweat during your session to help the body perspire more freely.
3. When the temperature reaches the level set on the control panel, the heaters will turn off and on periodically in order to maintain the desired temperature level inside of the sauna.
4. The **ceiling vent on the top panel can be opened** at any time **to introduce fresh air** into the sauna.

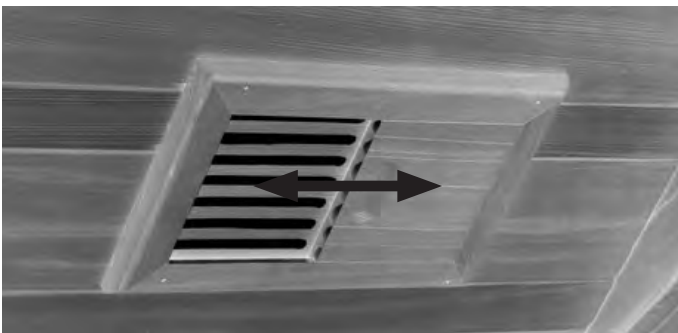

5. **If you feel the need for more cooling, simply leave the door open** until the air around you feels comfortable enough.

7. **Do not put any lotions or oils on the body or face** prior to using the sauna. This may block the pores and hinder perspiration.

8. **Essential oils** can help you to find more tranquility during your session. You can use our ceramic aromatherapy cup (optional accessory) to evaporate your favorite oils.

9. **To make the most out of your sauna session, work your muscles while in the sauna.** Stretch your arms, legs etc. to help relieve sore and tense muscles and massage the affected areas while in the sauna. If you wish to achieve a deep heating effect to a specific area, move it closer to a heater.

10. **Relieve your ankles and feet more effectively, you must elevate them while inside the sauna.**

11. **Shaving your face or legs** with a razor while profusely sweating in a sauna yields an incredibly smooth result without the use of gels or foams.

12. Do not forget to **drink plenty of water**, before, during and after sessions to replenish lost fluids through perspiration.

13. After the session is over, **do not immediately jump into the shower.** Since your body was heated up during the session, it will continue to sweat even after the heaters are off. **Sit in the sauna with the door open and let your body cool off.** Once you feel comfortable enough, take a warm (or cool) shower to rinse the perspiration off your body.



## d. safety precautions

### 1) general safety precautions

#### 1. Read Instructions

Carefully read all safety and operating instructions before operating your sauna.

2. Retain these safety and operating instructions for future reference.
3. Do not smoke or light any fire inside your sauna.
4. To reduce the risk of injury, do not allow small children to use the sauna unless they are closely supervised at all times.
5. Do not use the sauna immediately after hard exercise . Wait at least 30 minutes to allow your body to cool down completely.
6. Exercise care when entering or leaving the sauna.
7. Never sleep inside the sauna while the unit is in full operation.
8. Unplug the sauna from the wall outlet before cleaning. Use a damp cloth for cleaning. Do not use liquid cleaners or aerosol cleansers inside the sauna.
9. Do not use this product near water , for example near a bathtub, in a wet basement or near a swimming pool.
10. Do not use attachments that are not recommended by the manufacturer, as they may cause a hazard.
11. The sauna must be placed under an awning or overhang to prevent heavy rain falling directly onto the roof or outdoor cover.
12. Do not stack or store any objects on top of or inside the sauna.
13. Use precaution when using electronic devices.
14. Do not install aftermarket devices.

### 2) medical and health related precautions

1. If you intend to use far infrared therapy for medical reasons, please consult your physician prior to using the sauna.
2. Excessive temperatures have a high potential for causing fetal damage during the early months of pregnancy. Pregnant or possibly pregnant women should consult their physician prior to using the sauna.
3. The use of alcohol, drugs, or medications prior to or during the sauna session may lead to unconsciousness.
4. Persons suffering from obesity or with a medical history of heart disease, low or high blood pressure, circulatory system problems, or diabetes should consult a physician prior to using the sauna.
5. Persons using medications should consult a physician before using the sauna since some medications may induce drowsiness while others may affect heart rate, blood pressure, and circulation.
6. At the first sign of a cold or flu, increasing your sauna sessions may be beneficial in boosting your immune system and decreasing the reproductive rate of the viruses. Consult your physician for the proper treatment and care for this, before you start using your sauna.

#### 7. Hyperthermia Danger

Prolonged exposure to hot air will induce hyperthermia.

Hyperthermia occurs when the internal temperature of the body reaches a level several degrees above the normal body temperature of 98.6°F/37°C.

While hyperthermia has many health benefits, it is important not to allow your body's core temperature to rise above 103°F/39.4°C. Symptoms of excessive hyperthermia include dizziness, lethargy, drowsiness, and fainting . The effects of excessive hyperthermia may include failure to perceive heat, failure to recognize the need to exit, unawareness of impending hazard, fetal damage in pregnant women, physical inability to exit the sauna, and unconsciousness.



## d. safety precautions

### 3) power supply related precautions

1. **Dry your hands before handling electrical controls.** Never unplug the power cord or adjust the controls with wet hands or when you have wet bare feet. A danger of electrical shock exists.
2. **Your sauna is intended for use with a 3-wire properly grounded power socket.** Do not defeat the safety purpose of the supplied line cord and plug.
3. **This product should be operated only from the type of power source indicated on the marking label.** If you are not sure of the type of power supplied to your home, consult your local power company or electrician.
4. Power supply cords should be routed so they are not likely to be walked on or pinched by items placed upon or against them.
5. **For added protection during a thunder storm,** or when it is left unattended and unused for long periods of time, unplug it from the wall outlet.
6. **Do not overload wall outlets and extension cords** as this can result in a risk of fire or electrical shock.
7. **Always unplug this product from the wall outlet before servicing the product.**
8. **Do not remove power supply covers.** No user-serviceable parts are located inside the power supply.
9. **We strongly recommend the use of a GROUND FAULT CIRCUIT INTERRUPTER (GFCI) device** in any potentially wet locations.

### 2) warranty precautions

1. **When replacement parts are required, be sure to use replacement parts specified by the manufacturer** or have the same characteristics as the original parts. Unauthorized substitutes may result in fire, electrical shock or other hazards and will void the manufacturer's warranty.
2. If the power supply cord becomes damaged, it must immediately be replaced by the manufacturer or its agent or similarly qualified person to avoid hazard.
3. **Altering or tampering of any electrical connections** on the power supply will void the manufacturer's warranty.
4. **Do not attempt any repair without consulting the manufacturer first.** Unauthorized repair attempts will void manufacturer's warranty.
5. **All natural wood products have variations in the color, the grain, and irregularities such as knots, and fine cracks. These characteristics are a part of the natural beauty of the wood, and in no way should be considered defective.**
6. Upon completion of any service or repairs to this product by a service technician, ask the service technician to perform safety checks to determine that the product is in proper operating condition.





## e. troubleshooting guide

Question	Answer
<b>Control panel is beeping and showing an error message.</b>	<ul style="list-style-type: none"><li>• The temperature sensor inside your control panel housing has been disconnected. Remove control panel (video available) and confirm the two pin connection is securely fastened.</li></ul>
<b>There is no heat coming from my front heaters.</b>	<ul style="list-style-type: none"><li>• First thing you want to do is check the blue Molex connection inside the sauna. It's located on the bottom right of the sauna if you're sitting on the bench. You want to make sure that it is plugged in correctly. You will notice that the 2 outermost prongs on the connection have a rounded edge, while the center prong is a complete square. Be sure to match these plug shapes to the inlet for a proper connection.</li><li>• Check heater power cable connections.</li></ul>
<b>All other Sound System problems:</b>	<ul style="list-style-type: none"><li>• Unplug the sauna, wait 10 minutes, then plug back in.</li></ul>
<b>What are the electrical requirements for my new sauna?</b>	<ul style="list-style-type: none"><li>• Therapy Lounge: 220v, 15 Amp</li></ul>
<b>My new sauna is completely dead.</b>	<ul style="list-style-type: none"><li>• Make sure the power cord is plugged into the sauna power supply and the other end is plugged into the wall socket.</li><li>• Try pressing each of the 2 reset buttons on the sauna power supply.</li><li>• Unplug the sauna and plug something else, such as a lamp or radio, into the wall socket to verify there is power to that socket. If there is no power, check the house circuit breaker for that line.</li></ul>



## e. troubleshooting guide

Question	Answer
<p>The controller display is faint or does not display correctly in some other way.</p>	<ul style="list-style-type: none"><li>• Try unplugging the sauna for about 5 minutes, then plug it back in. This should correct any display problems.</li></ul>
<p>The sound system works, but nothing lights up on the controller display. I unplugged the sauna for 5 minutes but it didn't help.</p>	<ul style="list-style-type: none"><li>• Check to see that the data cable is plugged in at both ends- the round metal connector plugs into the "DATA" port on the power supply. The white plastic plug connects to the "DATA" socket on the front panel just above the floor.</li></ul>
<p>The sound system doesn't turn on.</p>	<ul style="list-style-type: none"><li>• Check to make sure the EXT plug is correctly plugged into the EXT socket on the back wall just below the ceiling. Look at the shape of the plug very carefully to make sure it conforms to the shape of the holes in the socket. There is only one correct way to plug it in, even though it is usually possible to plug it in wrong way.</li><li>• Check to make sure the EXT plug is plugged tightly into the EXT socket on the power supply under the bench.</li><li>• If the problem persists, please contact customer service.</li></ul>
<p>The LED light panel in the ceiling turns on white, but none of the buttons on the remote control work.</p>	<ul style="list-style-type: none"><li>• Make sure the thin plastic tab is pulled out from the battery holder.</li><li>• Make sure you are aiming the remote control at the center of the light panel, not at the sauna controller.</li><li>• Replace the battery in the remote control.</li></ul>



## e. troubleshooting guide

Question	Answer
<b>Wrong A.C. Power cord (female end of power cord does not match the male end of cable on sauna)</b>	<ul style="list-style-type: none"><li>• The power cord and the cable in the sauna floor near the power box do not attach or connect to each other. They both plug into the power supply located below the front heater (under a wooden cover).</li></ul>
<b>House circuit breaker is tripping.</b>	<ul style="list-style-type: none"><li>• Check that the amperage of the breaker corresponds with the amperage rating of your sauna. Make sure that the circuit is not overloaded by having too many appliances on one circuit. Please contact a local electrician.</li></ul>
<b>Where is the serial number on my new sauna?</b>	<ul style="list-style-type: none"><li>• Look for a manufacturer's label next to the DATA and HEATER sockets at the bottom of the front panel.</li></ul>

Please contact the manufacturer with any other questions regarding customer service or troubleshooting.



# e. wiring guide

Therapy Lounge	Data	Inlet	Heater 2	Heater 3	Heater 4	Bench	Lounge Bench
HM-NSE-5-CD-CL	Floor	Floor	Front Left Floor	Bench	Back Right Panel	Floor	Back Left Wall

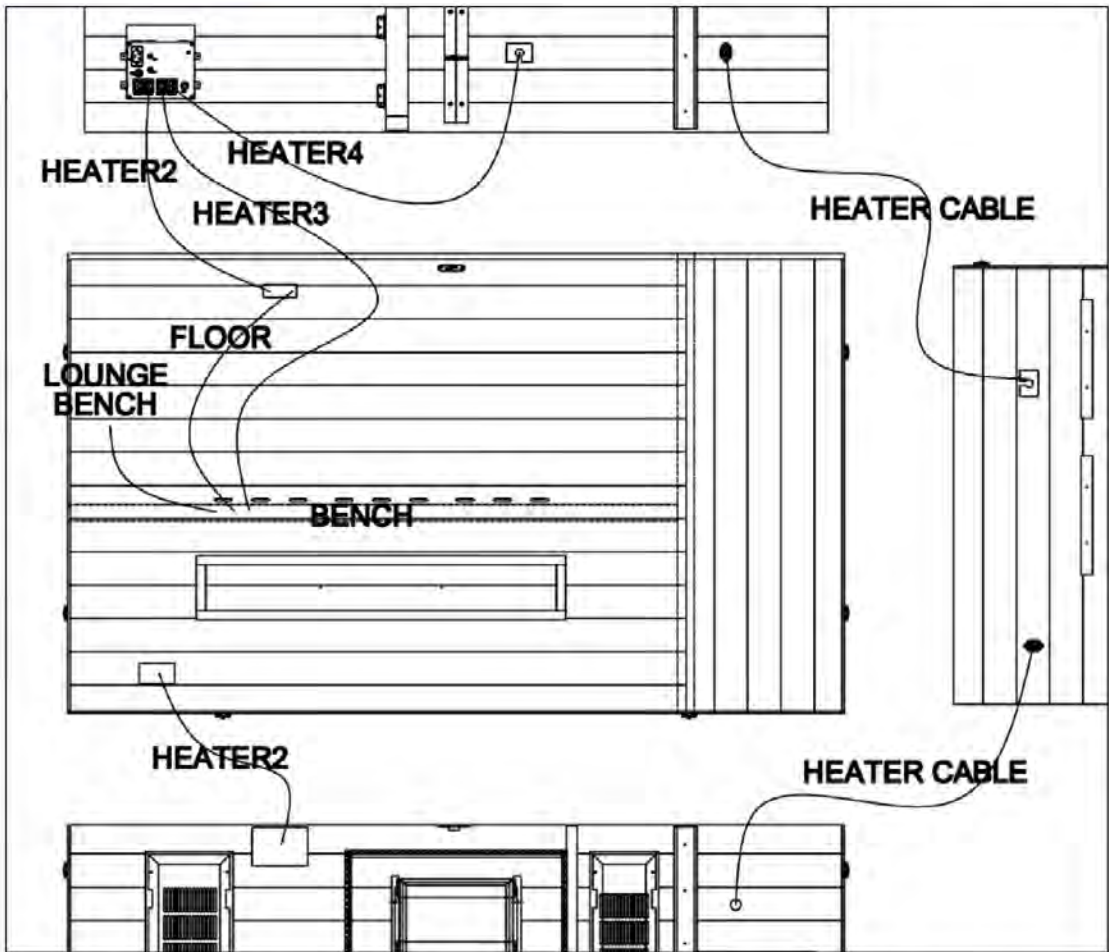



## f. optional accessories

### a) outdoor cover

#### 1. general information

The Health Mate sauna cover is designed to provide your sauna with extra protection against moisture and wind. It allows access to the sauna without having to remove the cover, and it comes with a 5-year limited warranty.

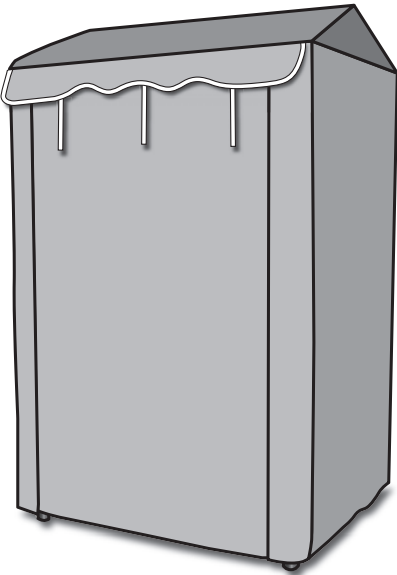

**Important:**

1. The **roof peak** must always be standing in the form of a letter 'A'.
2. The **sauna must be placed under an awning or overhang** to prevent rain falling directly onto the roof.
3. **Sauna should be placed** on sturdy, dry level ground when outdoors (not grass, gravel, dirt, etc.)
4. The **snap buttons** must be clipped on at all times.
5. The **zippers must be closed** when the sauna is not in use.
6. **Warm up times may vary** based on outdoor temperature.



The warranty on your sauna may become void if the cover is not properly installed or maintained.

Please follow these instructions step by step to install your outdoor cover.

#### 2. check for parts

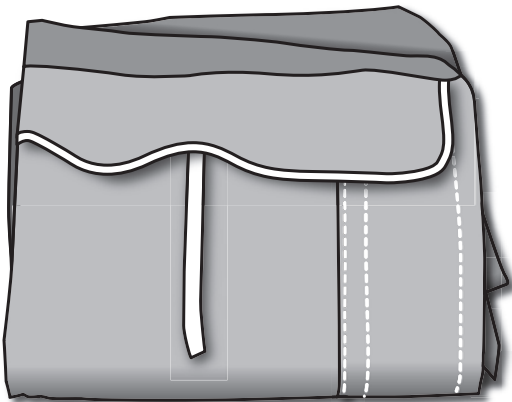

Sauna Cover



Snap-screws

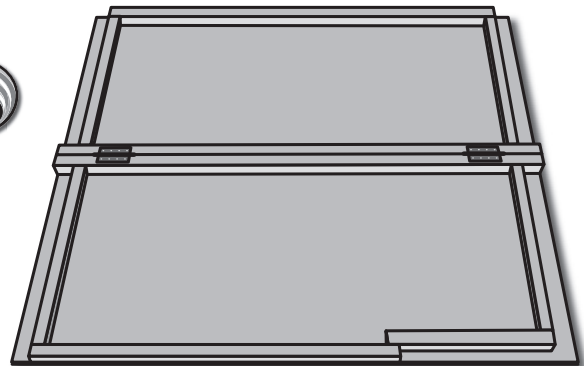

Wooden roof peak

**Tools:** the only tool you need is a Phillips screwdriver



## f. optional accessories

### 3. place the roof peak and prepare the cover

Carefully place the roof peak on top of the sauna.  
The roof peak must form a triangle when you see it from the side of the sauna.

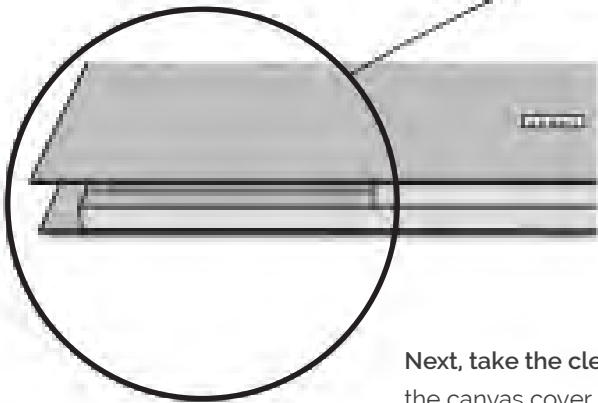

Next, take the clear plastic lining and cover the roof peak completely prior to installing the canvas cover.

Now **unfold the sauna cover and open the zippers** on the front section of the cover.

### 4. put the cover over the sauna

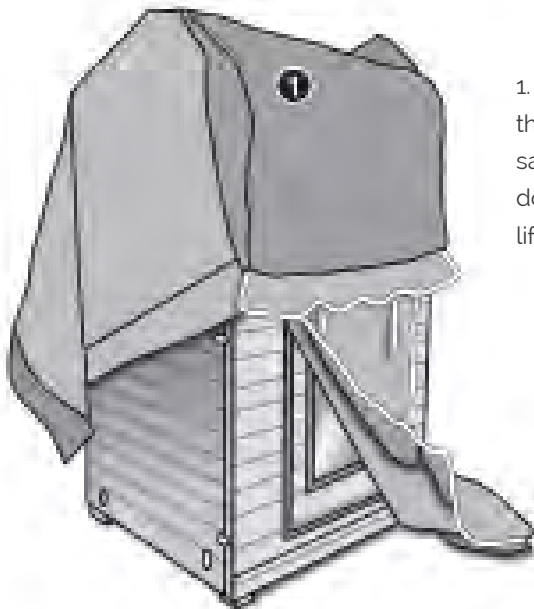

1. Take the back section of the cover and put it over the sauna. Pull the cover slowly down from the back while lifting up the front section.

2. Line up the seams with the edges of the sauna. Close down the zippers.





## f. optional accessories

### 5. attach the cover on the sauna

1. Tap hard on the snap buttons at each side of the cover, with the back of your screw driver to leave a mark on the wood.

2. Lift up the cover and screw on the snap-screw at the center of the mark.

Lower down the cover of both sides and snap the buttons on until you hear a click.







## f. optional accessories

### b) accessories

---

#### 1. aroma mate

Adding just a few drops of essential oils to your Aroma Mate aromatherapy cup will transform your warm space to a calming place. Visit your health food store for non-diluted and non-alcoholic quality essential oils. This accessory does not require any assembly.

---



#### 2. floor mate

**Dimensions** (width x depth x height):

Medium – 24 X 18 X 1.25 | Large – 36 X 18 X 1.25

The floor mat is designed to be put outside in front of your sauna door. This accessory does not need any assembly.

---



#### 3. mini mate

**Dimensions** (width x depth x height): 40 x 40 x 45 cm

The benches are easily assembled with a Phillips screwdriver and a wrench.

---



#### 4. shelf mate

This accessory can be easily assembled with a Phillips screwdriver. The shelf is simply attached on the outside of your sauna, with two metal hooks between the roof and wall top.





## g. limited warranty

### PLEASE REGISTER YOUR PRODUCT PURCHASE WITH THE MANUFACTURER

Go to [healthmatesauna.com/resources/warranty-registration/](https://healthmatesauna.com/resources/warranty-registration/) to register in minutes.

PLEASE READ THIS LIMITED WARRANTY IN ITS ENTIRETY TO UNDERSTAND YOUR RIGHTS AND OBLIGATIONS. The warranty below applies to all saunas purchased AFTER 2024. For saunas purchased in 2024 and before, contact us for legacy terms.

#### Health-Mate Sauna 10-Year Limited Warranty:

The Company agrees to repair or replace the products listed in the "Warranty Coverage Guide" for the coverage period specified and hereby referred to as the "warranty period". The products listed are covered subject to and solely in accordance with the terms and conditions, exclusions and limitations set forth herein.

#### LIMITED WARRANTY ON SAUNA CABIN, FRAME, HARDWARE & COMPONENTS

The Company warrants to the registered customer during the warranty period the following:

- (A) The sauna frame inclusive of the walls, floor and ceiling will maintain structural integrity.
- (B) The sauna hardware and components which include the heater, heater controls, power supply, electrical wiring, lighting hardware, and audio components will be free from defects in material, workmanship, or functionality.
- (C) Any required LABOR for the replacement of parts associated with the sauna cabin, frame, hardware & components are covered under the Company's labor warranty for the specified warranty period.

#### LIMITED WARRANTY ON NON-FACTORY INSTALLED PARTS, COMPONENTS, OPTIONS, AND ACCESSORIES

Any and all non-factory installed parts, components, options, and product accessories are not considered warranted to the customer against defects in material or workmanship except to the extent of any warranty period expressly set forth in the purchase agreement or invoice unless otherwise noted in writing at the time of sale of the product(s) between the Company and the Customer.

#### DISCLAIMER OF IMPLIED WARRANTIES

ALL IMPLIED WARRANTIES, INCLUDING WITHOUT LIMITATION, THE IMPLIED WARRANTIES OF MERCHANTABILITY AND FITNESS FOR A PARTICULAR PURPOSE ARE HEREBY DISCLAIMED IN THEIR ENTIRETY OR TO THE FULLEST EXTENT ALLOWED BY LAW. THIS LIMITED WARRANTY TAKES THE PLACE OF ALL OTHER WARRANTIES, EXPRESS OR IMPLIED, IN FACT OR AT LAW, INCLUDING IMPLIED WARRANTIES OF MERCHANTABILITY AND FITNESS FOR A PARTICULAR PURPOSE.

#### WARRANTY LIMITATIONS AND EXCLUSIONS

The warranty period commences on the date of purchase by the customer. The period in which the product is delivered or picked up by the customer prior to installation is also covered under the warranty period. This warranty may not be transferred, sold, gifted, or modified. It may be assigned however only through a re-registration of ownership which can be done at [healthmatesauna.com/resources/warranty-registration/](https://healthmatesauna.com/resources/warranty-registration/). The assignment will undergo review and approval prior to its completion and commencement. The approval of the transfer is at the sole absolute discretion of the Company. Any cause of defect, damage, or compromise to the product upon any physical relocation, shipment, or delivery performed by the customer or third party service provider performed under any approved assignment or transfer is not covered under the warranty. Unless successfully assigned and approved by the Company, only the original purchaser can make claims hereunder. All warranty labor must be performed by the Company or its designated representative, contractor, or service provider serving as an authorized representative or agent of the Company.



## g. limited warranty

No retailer, influencer, affiliate, agent, distributor, dealer, service company, or other third party is authorized to change, modify, or extend the terms of this limited lifetime warranty in any manner whatsoever. Any warranty provided outside the scope of this warranty shall be solely their separate obligation and in no way enforceable to the Company. For the purposes of clarity, certain words and phrases used in definition of this warranty are hereby referred to as the following:

- (A) "Company"- shall mean Health-Mate Sauna.
- (B) "Customer"- shall mean the original purchaser.
- (C) "Purchaser"- shall mean the original customer.
- (D) "User"- shall mean the original purchaser.
- (E) "Residential Use"- shall mean the original purchaser for use is by an individual, single family, or household group for internal household purposes.
- (F) "Commercial Use"- shall mean any use that involves a fee, rate, charge, or other consideration, any use directly or indirectly in connection with a business, institution, going concern, or undertaking intended for profit, gain, or monetization, and non-residential use.

This limited warranty shall not apply to any display model, refurbished model, or used model unless expressly agreed to by Health-Mate Sauna in writing at the time of purchase. The new owner/user will need to register the product in order to effectuate the warranty under any approved agreement.

The limited warranty does not cover defects, damages, or failure ("Damage") caused by the delivery service providers or common carrier, the installer, user, or other persons. Any impact from animals, including without limitation, termites and other wood-destroying insects or rodents are not covered. The limited warranty excludes Damage resulting from transportation, careless handling, improper location, storage, or relocation, as well as from cleaning, painting, staining or other use of abrasive or improper chemicals. The limited warranty also excludes Damage arising from user's or a third party's negligence; modification of any type for any reason (including modification to meet local building codes); improper installation (including installation not in accordance with instructions and specifications provided with the unit); connections supplied by the installer of the equipment, an electrician or a third party; improper voltage supply; unauthorized electrical modification; misuse; improper use; abuse; incorrect operation, lack of proper routine or preventive maintenance; unauthorized repair by a third-party; normal wear and tear; fire, and acts of God such as lightning, floods, earthquakes, etc.

The limited warranty does not include: labor, transportation, or other costs incurred in the removal and/or reinstallation of the original unit and/or installation of a replacement unit. Any costs relating to obtaining access for repair; or loss of use damage, including loss of sales, profit or business advantage of any kind under any circumstances will also not be covered. The labor warranty is provided in the United States of America and Canada only. User shall be obligated to pay for postage, shipping and handling for mailing and delivery of any products or components outside the United States and Canada. Timely registration of product and purchase is required for a warranty claim. User's can go to [healthmatesauna.com/resources/warranty-registration/](http://healthmatesauna.com/resources/warranty-registration/). Or call Health-Mate Sauna at 1-800-946-6001 to register their products(s). These disclaimers shall be equally applicable to any labor or service provided by Company and its designated representatives.

### RESPONSIBILITIES OF OTHERS

Unless provided by the Company or otherwise expressly agreed to in writing, the separate role of proper qualifying, hiring, firing, managing, and compensation of third party installers or service providers are the exclusive responsibility of the user. Any potential liabilities associated or incurred as a result of the utilization of user's installer are the responsibility of the user. The user will have



## g. limited warranty

no recourse with the Company and the Company will have not obligation, liability, or responsibility in connection with the same. User's installer is responsible for inspecting the unit prior to installation and ensuring that the unit is free of defects or damages. Notifications accompany the product shipped advising the installer of these responsibilities. In the event a problem is identified prior to the installation, the unit must not be installed, and the Company must be notified immediately. The Company is not responsible for damages that could have been discovered, repaired, or avoided by proper inspection prior to the installation. Any damage occurring in transit is the responsibility of the carrier. The user or installer MUST open the package(s) or pallet of product(s) and inspect the unit for damage when it is delivered. If damage is discovered, it must be reported to the Company or seller and the carrier in writing, and an inspection must be requested. Any failure of the carrier to respond should be reported to the Company or seller and the carrier. Customer freight claims should be filed promptly thereafter. Damage occurring to the unit during installation is the responsibility of the installer and/or building contractor and any damage occurring thereafter is the responsibility of the user. Failure of any non-factory installed parts, components, and accessories are the sole responsibility of the equipment manufacturer except as provided above. Any replacement parts shall be covered only by the original equipment manufacturer (OEM) warranty, if any. The customer's installer is responsible for knowing local code requirements and installation safety protocols in accordance with the same. The Company is not responsible for costs to modify any product to obtain any code approval, such as city, county, or state building codes.

### **WARRANTY REGISTRATION**

The company encourages every customer to immediately register their product(s) within 10 days after delivery. To register your product, please go to [healthmatesauna.com/resources/warranty-registration/](http://healthmatesauna.com/resources/warranty-registration/). Once you arrive at the company's website, you will then be prompted to enter your product Serial Number followed by your warranty registration information.

### **WARRANTY SERVICE**

For the user's benefit, the Company maintains a list of independent service personnel to perform required warranty service repairs. Such firms are not agents or representatives of the Company and cannot bind the Company by words or conduct. Please note that in very rare cases, certain geographies may not have a Company qualified designated independent service provider. In this event, the Company will assist in sourcing one within a timely manner and will work with the user to reconcile the matter through a swift collaborative effort. The Company will provide the warranty service described above when the following conditions have been met: the failure is covered by the warranty; the user has informed an Authorized Health-Mate Sauna Warranty Service Department Representative of the nature of the problem during the warranty period; conclusive evidence (e.g., proof of purchase or installation) is provided to the foregoing by the user proving that the failure occurred or was discovered within the warranty period; and, an authorized independent service person or Company representative has been permitted to inspect the unit during regular business hours within a reasonable time after the problem was reported by the user. In order to obtain warranty service, contact Health-Mate Sauna at:

[www.healthmatesauna.com](http://www.healthmatesauna.com)  
Health-Mate Sauna  
10541 Calle Lee STE 119  
Los Alamitos, CA 90720  
Phone: 1.800.946.6001  
Fax: 1.714.739.6605  
[info@healthmatesauna.com](mailto:info@healthmatesauna.com)



## g. limited warranty

To obtain warranty service, call or write to the above. Provide a description of the problem and proof of purchase. You will be instructed how to obtain replacements and where to return, at your expense, the failed component(s), option(s), or accessory(ies). All replacement parts, equipment, and repairs shall assume the remaining warranty period of the part(s) replaced and do not extend the same. The Company's warranty obligation shall be discharged upon tender of replacement or repair. The customer's refusal to accept the tender terminates the Company's warranty obligation. The Company will only pay for shipping and handling fees to return the repaired or replacement unit to the user if the Company elects to replace the defective unit.

**LEGAL RIGHTS:** This Limited Lifetime Warranty provides the customer with specific legal rights. The warranty obligations are provided by Health-Mate Sauna and its affiliates. There are no warranties applicable to Health-Mate Sauna products manufactured and distributed by the Company, except as expressly stated herein or as implied by applicable state and federal laws. The customer may also have other rights that vary from state to state and it will be up to the customer to learn and understand those rights. Certain states may not allow limitations on how long an implied warranty is applicable, disclaimer of certain warranties, or the exclusion or limitation of incidental or consequential damages. Therefore, it is possible that the aforementioned limitations and exclusions may not be applicable to certain customers. The Company will not be responsible for any statements or representations or misrepresentations made in any form that go beyond, are broader than, or are inconsistent with any technical specifications furnished by the Company.

### **LIMITATION OF LIABILITY**

THE REMEDIES DESCRIBED IN THIS LIMITED WARRANTY ARE YOUR SOLE AND EXCLUSIVE REMEDIES AND THE COMPANY'S ENTIRE LIABILITY, INCLUDING, WITHOUT LIMITATION, FOR ANY BREACH OF THIS LIMITED WARRANTY. COMPANY'S LIABILITY SHALL UNDER NO CIRCUMSTANCES EXCEED THE ACTUAL AMOUNT PAID BY USER FOR THE APPLICABLE DEFECTIVE PRODUCT, NOR SHALL COMPANY UNDER ANY CIRCUMSTANCES BE LIABLE FOR ANY CONSEQUENTIAL, INCIDENTAL, SPECIAL OR PUNITIVE DAMAGES OR LOSSES, WHETHER DIRECT OR INDIRECT. IN ADDITION, THE COMPANY WILL NOT BE RESPONSIBLE FOR CONSEQUENTIAL, INCIDENTAL, SPECIAL OR PUNITIVE DAMAGES OR LOSSES, WHETHER DIRECT OR INDIRECT FROM ANY CAUSE WHATSOEVER, INCLUDING BUT NOT LIMITED TO COMPANY'S GROSS NEGLIGENCE. THIS EXCLUSION APPLIES EVEN IF THE COMPANY WAS ADVISED IN ADVANCE OF THE POSSIBILITY OF SUCH DAMAGES. SOME STATES DO NOT ALLOW THE EXCLUSION OR LIMITATION OF INCIDENTAL OR CONSEQUENTIAL DAMAGES, SO THE ABOVE LIMITATION OR EXCLUSION MAY NOT APPLY TO YOU.



## g. limited warranty

<b>Health Mate Sauna: Limited Lifetime Warranty</b>	<b>Indoor Residential Use</b>	<b>Indoor Commercial Use</b>
<b>Product</b>		
Health-Mate Sauna Cabin & Frame	Lifetime	1 year
Health-Mate Sauna Vertical Paneling	Lifetime	1 year
Health-Mate Sauna Flooring and Baseboard	Lifetime	1 year
Health-Mate Sauna Door/ Glass/ Hinges	Lifetime	1 year
Health-Mate Sauna Handles & Fixtures	Lifetime	1 year
Sauna Electronic Controls & Wiring	Lifetime	5 year
Heater Core, Harness, and Wiring	Lifetime	5 year
Interior Lighting Fixtures and Wiring	Lifetime	5 year
Exterior Lighting Fixtures and Components	Lifetime	5 year
Interior Audio Fixtures and Components	Lifetime	5 year
Labor of Factory Installed Components	Lifetime	5 year
Upgrades, Options, Parts & Accessories	Per Manufacturer's Warranty Unless Otherwise Noted at Sale or Contract	



# g. limited warranty

For your record, please complete the following information.  
You will need to refer to this information when calling customer service:

Date of Purchase: \_\_\_\_\_ Date of Delivery: \_\_\_\_\_

Model Number: \_\_\_\_\_ Serial Number: \_\_\_\_\_

Dealer Information (Name & Telephone): \_\_\_\_\_  
\_\_\_\_\_  
\_\_\_\_\_  
\_\_\_\_\_

Where is the serial number on my new sauna? Look for a manufacturer's label next to the DATA and HEATER sockets at the bottom of the front panel.

Address: 1329 Gateway Drive, Gallatin,  
TN 37066

Fax #: 714.739.6605

Toll Free #: 800.946.6001

Email: support@healthmatesauna.com

healthmatesauna.com



**HEALTH MATE**

---

800.946.6001 | [healthmatesauna.com](http://healthmatesauna.com)